

MPEG Analyzing Platform

MAP 1853

The MAP 1853 is Sencore's high performance MPEG analyzer supporting MPEG-2, DVB, ATSC and ISDB standards.

Designed to give you a complete solution to these questions:

-How do you create custom transport streams to test your IRDs?

-What process you do use to be certain your equipment is compliant to the standards?

-How do you solve interoperability problems? How important is it to know what makes that signal different?

-How do you plan to test new technologies like IP over MPEG or data broadcasting?



The MAP 1853 is a powerful, modular MPEG-2 analyzing platform can help solve your transport stream problems by allowing you to:

-Creating

-Generating

-Monitoring

-Analyzing

Designed around a solid hardware platform, the unit provides you with the flexibility to fill any application need from a simple streamer to a complete, detailed analysis tool.

The MAP 1853 is based on a server/client architecture allowing multiple users to run the applications from their remote PC over Ethernet.

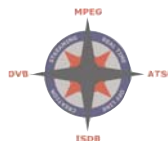

STREAM CREATING

The MAP 1853 allows the creation of transport streams (TS) for generating test files. The **Stream Creator** software suite offers applications to multiplex multiple elementary streams (ES), insert and modify SI/PSI and PSIP, and even define private sections. The MAP 1853 also allows the editing of every packet for error inserting or specific byte modification.

The MAP 1853 can automatically calculate important parameters such as bitrates, table repetition or PCR. If needed, you can modify any elements of the TS using many different tools provided. Jitter can also be added to the signal for stress testing of downstream equipment.

The MAP 1853 supports any Transport Stream with MPEG-2, DVB, ATSC or ISDB syntax.

GENERATING

Player/Recorder

The MAP 1853 is capable of playing and recording simultaneously multiple transports stream (TS) for test generation purpose. The MAP 1853 supports total bitrate playout of 320Mbits/s across the different I/Os. Its one-bit resolution makes it one of the fastest and most accurate MPEG analyzers available. The player/recorder application provides scheduled playback, recording and smart seamless looping.

The MAP 1853 can be configured with multiple interfaces including ASI, SMPTE310M, LVDS or DHEI. The modular design of the MAP 1853 allows for new interfaces to be fitted as they are developed.

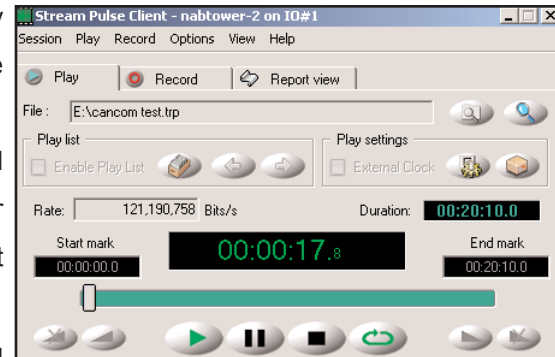

Player Recorder Application

Real Time Multiplexer

The MAP 1853 has the capability to multiplex, in real time, multiple elements such as elementary streams, SI/PSI and PSIP. The **Real Time Multiplexer** application also allows modification of the output bitrates, PID and program remapping as well as modification to the tables on the fly. This application extends the generation capabilities of the MAP 1853 by providing quick generation and playout of test streams.

The MAP 1853 supports the ISDB standard. The **ISDB Tools** option offers an ISDB multiplexer, de-multiplexer and allow playout, recording of ISDB streams.

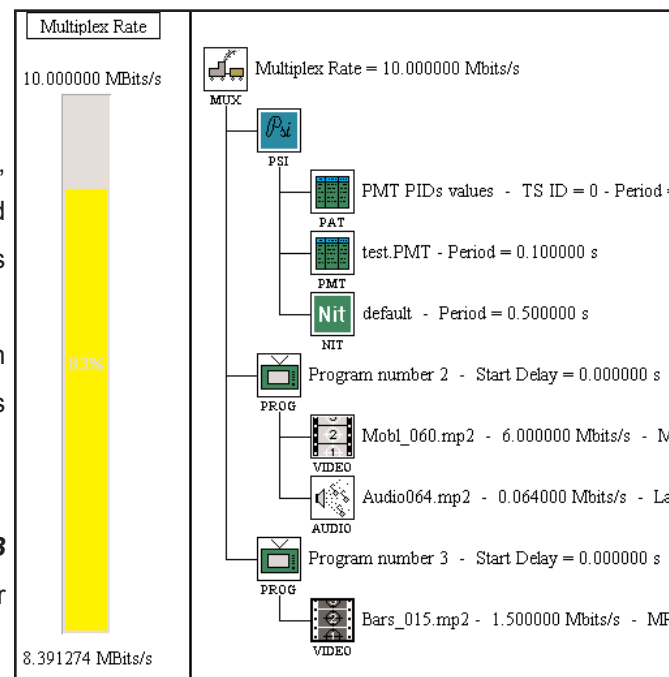

Multiplexer Application



MONITORING

Real Time MPEG-2 Analysis

The MAP 1853 offers detailed real-time MPEG-2 analysis of a TS at the ASI maximum bitrate of 214Mbits/s. The **Real Time MPEG-2 Analysis** application tests for compliance with the MPEG-2, DVB, ATSC and ISDB standards. It is also compatible with Digicypher-II systems. This application also supports emerging technologies such as Data Broadcast, MHP, WM9 and H264.

TR101290 Measurements

The MAP 1853 makes TR101290 measurements including PCR Jitter, PTS and DTS measurements. Each measurement is provided with a Go/No-go LED as well as a graph for more details. It also provides a detailed section view of the tables as well as repetition rates of each section. All measurements and errors are logged by user-defined categories for easy review. The MAP 1853 can also monitor user-defined private syntax.

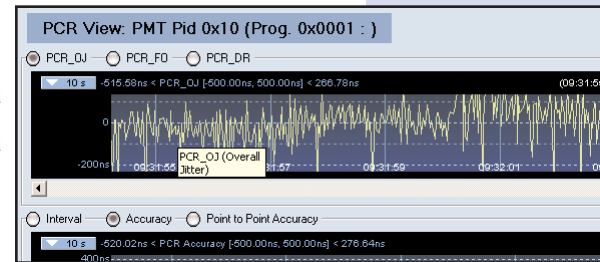

Bitrate Monitoring

The MAP 1853 measures bitrates of every program and PID present in the transport stream. With a one bit resolution, the MAP 1853 makes an extremely accurate bitrate measurements. The MAP 1853 can graph, in real-time, any PID or program for long-term bitrate monitoring. This feature, for example, allows for monitoring of opportunistic data bandwidth.

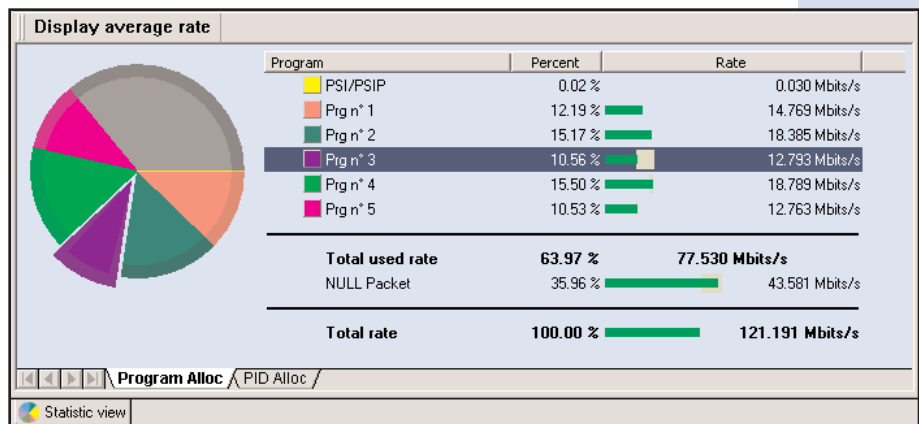

Multiplex Real Time Monitoring

Logging and Error Trigger Recording

The MAP 1853 has extended error logging and condition logging capabilities. The logs are fully configurable and searchable by program, PID or error type. The file-capture-on-error feature allows for easy troubleshooting of intermittent problems. Bitrate logging allows the collection of data over a long period of time. All created logs can be exported to a spreadsheet format.

DTV functions

The MAP 1853 has specific tests and features to help troubleshoot DTV. The Real Time Monitor offers EPG display, for easy PSIP table troubleshooting. It provides closed caption analysis as well as video and audio decoding of HD and SD.



Data Real Time Analysis

The MAP 1853 offers detailed real-time IP over MPEG analysis of a TS at maximum ASI bitrates up to 212Mbits/s. The **Data Real Time Analysis** application tests for compliance of any incoming TS following the DVB or ATSC standard. It is also compatible with Digicypher-II systems. This application also supports emerging technologies such as Data Broadcast and MHP.

IP over MPEG Measurements

The MAP 1853 supports MPE, data piping, addressable sections, JSAT and data streaming. It provides a detail view of each packet syntax including UDLR and DTCP Hello Messages. A filtering mechanism allows monitoring of QoS for each customer receiving the IP. This can be used for bandwidth billing purposes.

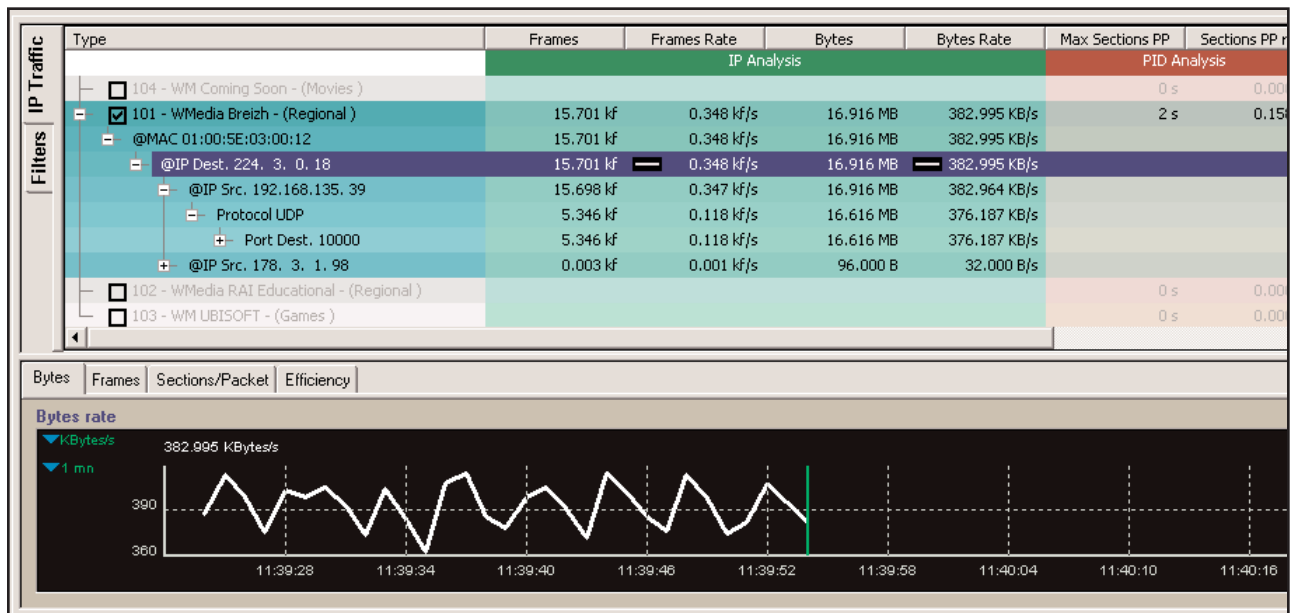

IP over MPEG Bandwidth Display

De-encapsulation of the IP Data

The MAP 1853 can select a specific IP traffic, extract the content and save it to disk for IP analysis using Netmonitor. It can also forward the IP traffic to the built-in Ethernet port, providing IP routing capabilities. The MAP 1853 can be used in conjunction with an IP analyzer for complete end-to-end monitoring and troubleshooting.

Bitrate and Overhead Monitoring

The MAP 1853 monitors all the services and PID bandwidth with 1-bit accuracy. The MAP 1853 makes encapsulation overhead measurements for bandwidth optimization. This allows the user to modify encapsulation equipment configuration and verify, in real-time, the effects of the changes.



Real Time MPEG over IP analysis

The MPEG over IP real time analyzer performs cross-layer analysis of MPEG content streamed over IP.

This allows you to detect IP errors and its impact on the transport stream. Measurements performed

include:

- Packet loss
- IP statistics
- Consistency check
- Session announcement and description analysis
- Specific MPEG-2 analysis

Detail bitrate analysis, crucial for bandwidth management, can be performed over a long period of time.

Every detected error is logged for troubleshooting purpose. The integrated Real Time IP Stream Analysis combined with the MPEG-2 Real Time Analyzer provides a complete cross layer analysis of the incoming MPEG-2 transport stream within the IP stream.

Hierarchy	Frames	Frames Rate	Bytes
Connection Mode			
+ Ip Dest @ 178.3.3.63	0.514 Kf	7 f/s	222.7
+ Ip Dest @ 178.3.250.34	18.000 f	1 f/s	832
+ Ip Dest @ 178.3.250.126	0.347 Kf	4 f/s	13.7
+ Ip Dest @ 178.3.255.255	0.118 Kf	0 f/s	20.5
+ Ip Dest @ 224.0.0.4	4.000 f	0 f/s	128
+ Ip Dest @ 224.10.10.10	0.014 Mf	161 f/s	17.3
+ Ip Dest @ 224.10.10.11	1.000 f	0 f/s	32
+ Ip Dest @ 224.10.10.12	1.000 f	0 f/s	32

MPEG over IP signaling Display

Forwarding the Transport Stream

You have the capability to select an IP service and extract the MPEG transport stream. The transport stream can then be directed to a physical transport stream output such as ASI, LVDS, SMPTE310M or DHEI. The Transport stream can then be directed to a decoder.

Play/Record

The MPEG-2 transport stream contained in the incoming IP stream can be recorded on the hard disk for detailed offline analysis or for later playback. A MPEG-2 transport stream can be encapsulated into an IP stream on the fly and streamed through the IP interface. The MPEG-2 transport stream can be prerecorded on the hard disk and can be streamed using the IP Player to a unicast or multicast address with the following specific encapsulation properties:

- SAP/SDP announcement
- Unicast/Multicast
- UDP/RTP

This function allows for IP equipment to be tested by generating a known test signal.



Real Time MHP Stream Analysis

The MHP real time analyzer performs real time analysis of interactive content streamed on a MPEG-2 transport stream. This allows you to detect errors in the signaling and delivery of interactive applications. Measurements performed include:

- AIT and DSM-CC U-N messages syntax analysis
- Data carousel analysis and display
- Object carousel mounting
- Statistics
- Consistency check
- Compliance testing to the MHP 2.2 specifications
- Dynamic monitoring of events

Detailed bitrate analysis, crucial for bandwidth management, can be performed over a long period of time. Every detected error is logged for troubleshooting purpose.

The real time MHP analyzer is a must have for any engineer involved with interactive TV design or broadcast. It provides all the necessary tools to troubleshoot interactive applications built around MHP or OCAP.

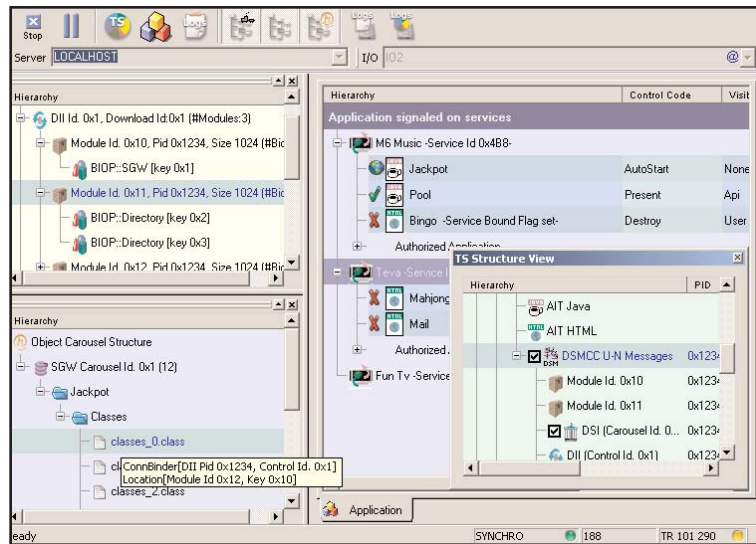

Object and data carousel linkage

MHP Off-line Analysis and Stream Creation

The MAP 1853 in conjunction with the MHP real time analysis offers MHP off-line analysis and stream creation capabilities.

Some of the off-line analysis features include:

- MHP tables and descriptors analysis, display and saving
- DSM-CC messages analysis, display and saving
- Navigation through the stream components
- Stress functions including packet loss and jitter

Some of the stream creation features include:

- Editor for MHP tables and descriptors
- Ability to multiplex them along with DSM-CC sections

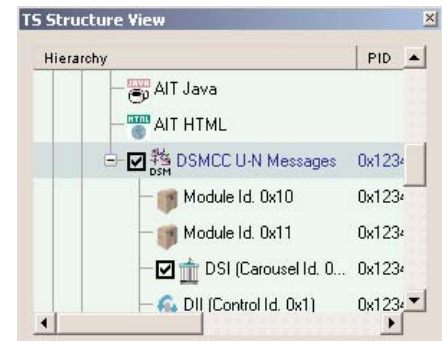

ANALYZING

Extended Offline Analysis

The MAP 1853 offers detailed off-line analysis of the MPEG-2 transport stream. The **Extended Real Time Analyzer** application provides detailed intuitive packet and syntax analysis for non MPEG-2 experts. This application provides you with a description of all the bits within each packet, as well as detailed PCR analysis.

The offline analysis allows the extraction of the TS, table or PES information. An automated test sequence can analyze in detail all aspects of the transport stream and provide a report of every error, layer by layer.

The offline analysis allows you to extract any elementary stream (ES) from a transport stream for re-multiplexing with the **Stream Creator** tools or the **Real Time Multiplexer**.

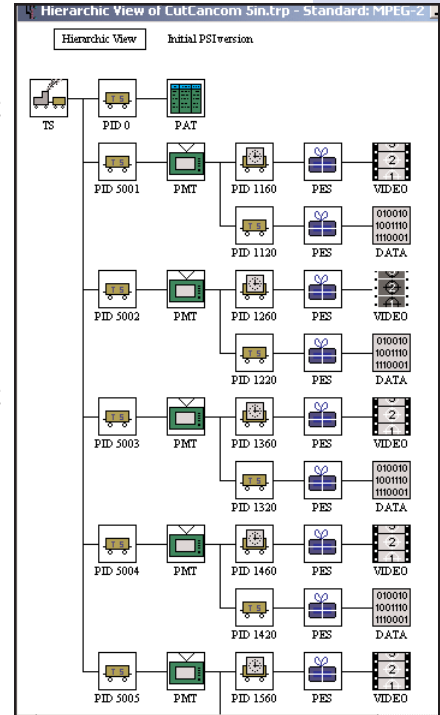

Conformance testing

The MAP 1853 provides a very in-depth conformance testing of the transport stream under investigation. Each component of the syntax is carefully analyzed and any error is logged and referenced to the exact packet where the error has been detected.

A simple double click on the error takes the user to the corresponding bad TS or PES packet and provide a description of the error.

When your equipment passes the conformance test of the MAP 1853, you are ensured that it meets the standards and is ready to move from the lab to the real world.

Video and Audio Elementary Stream Analysis

The MAP 1853 provides two options for video and audio elementary stream analysis. The **Standard ES Analysis** provides information about the video ES header and control bits. It shows and displays GOP headers, as well as decoded I frames. It analyzes the ES header and syntax of MPEG-1 layer 1 and 2 audio.

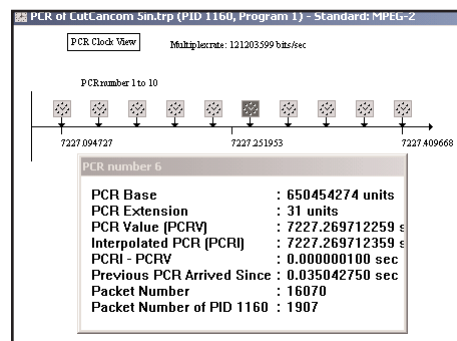

Detailed PCR Analysis



Closed Caption Analysis

The MAP 1853 offers detailed analysis of the closed caption embedded in the MPEG-2 transport stream following the EIA-708B standard. The **Closed Caption Analysis** application can extract and decode NTSC services as well as the DTVCC services embedded in the transport stream. It will overlay, on the video, the selected closed caption services on a frame by frame basis. A detailed analysis of the closed caption encapsulation allows decoder and encoder designers to verify the validity of the complex closed caption implementation.

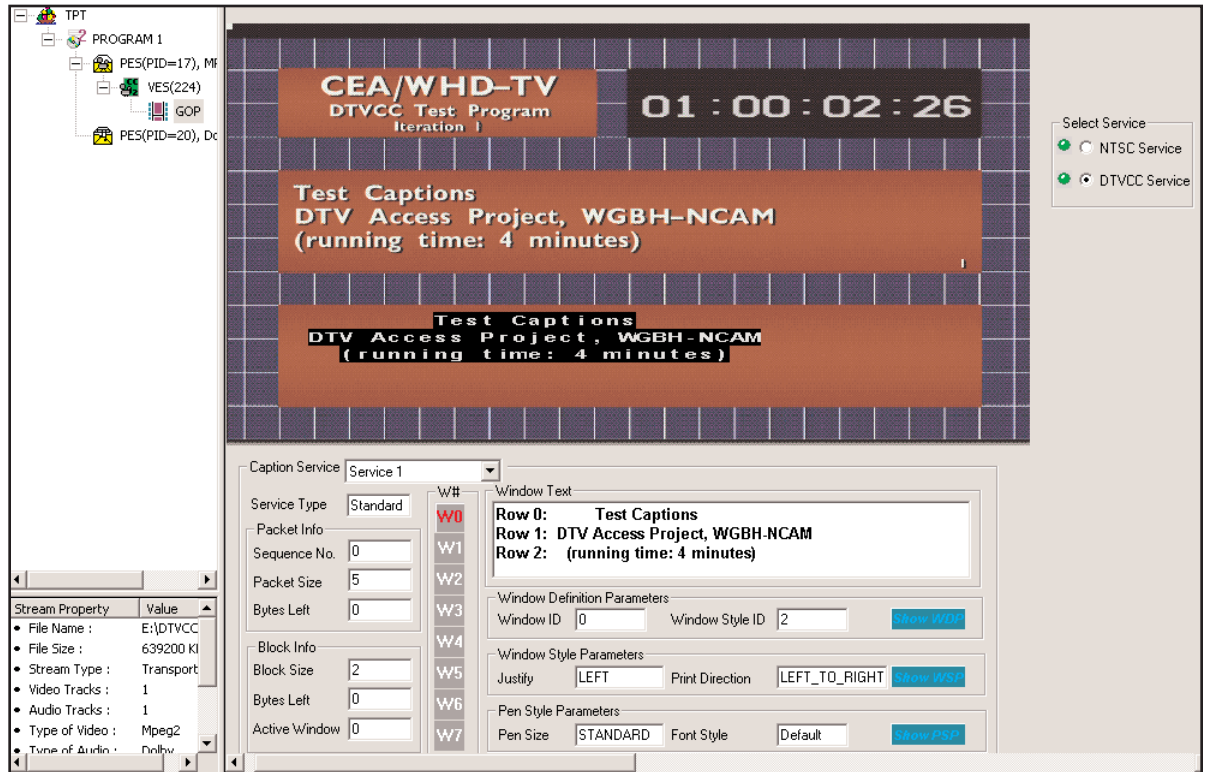

Closed Caption analysis

Program Stream Analysis

The MAP 1853 provides the analysis of program streams which are used in DVD applications. The MAP 1853 analyzes the syntax and structure of the program stream. The **Program Stream Analysis** application is capable of extracting the elementary stream from the program stream. The elementary stream can then be used by the **Stream Creator** application to create a new transport stream. This application can be used to create transport streams from non-encrypted DVD content.

Transport Stream Library

The MAP 1853 is provided with a set of transport streams including DVB, ATSC, MPEG-2, ISDB test streams. These test streams are designed to provide you with a known base library of test streams. The MAP 1853 also provides Data Broadcast test streams by offering DSMCC and MPE transport streams.



Applications for the MAP 1853

The MAP 1853 is a versatile and modular MPEG-2 Analyzing Platform and fits the need of many applications where MPEG-2 transport streams are present. Applications range from R&D to field services with all the steps in between.

Development

The MAP 1853 is designed to be used in DTV labs. With the capability of playing and analyzing up to 4 TS streams at bitrate up to 212Mbits/s simultaneously (total of 320 Mbits/s), it provides a powerful diagnostic tool to any digital Video Engineer. Each bit can be parsed and analyzed from the Transport Stream packets to the DCT coefficients of the video compression.

DTV Broadcast Environment

With the implementation of complex DTV equipment, the broadcasters need a rapid, easy to use analysis tool to pinpoint errors and potential interoperability problems in their system. The MAP 1853 offers all the necessary tools to achieve a compliant ATSC transmitted signal. It also provides detailed monitoring on PSIP, bitrate allocation and even data broadcast.

IP over MPEG providers

The MAP 1853 is designed to offer providers of IP over MPEG with a detailed troubleshooting tool. It also provides an easy way to monitor bandwidth delivery of each service to each customer or group of customers for billing application for example.

MPEG over IP providers

The MAP 1853 is designed to offer providers of MPEG over IP with a detailed troubleshooting tool. It also provides an easy way to monitor bandwidth, multicast and unicast IP addresses.

Manufacturing

The MAP 1853 is suitable for manufacturing/QA and repair facilities as it provides a fixed, well known, easy to operate Transport Stream signal source used to verify that the products under test operate as desired. The networking capabilities of the Transport Streamers allow the engineer to upload test content to the manufacturing line without having to physically be present. In case of hard to solve problems, the analysis portion of the MAP 1853 ensures low down time of the production line.

System integration

The MAP 1853 is designed for signal path testing as it can simulate a well-known error free transport stream output as well as analyze an incoming signal. With all the potential interoperability issues, the MAP 1853 will ensure a fast and reliable integration of different technologies.

Also, as the MAP 1853 supports MPEG-2, DVB, ATSC and ISDB standards, you can be assured that it will be compatible with the equipment that is being deployed in digital facilities.

Field support and repair

The field support engineer often needs to analyze signals from and to the equipment under test and make quick diagnostics of the problems in an environment where down time isn't acceptable. The MAP 1853 offers all the necessary tools for field analysis and troubleshooting. It also allows capture of a Transport Stream for analysis back at the office.



Specifications

Interfaces Specifications:

ASI	188-204-208	214 Mbits/s
SPI(Parallel)	188-204-208	80 Mbits/s
SMPTE310M	188	19.392658 or 38.785317
DHEI	188-192-204-208	44 Mbits/s
Total bitrate across all I/Os		320 Mbits/s

External Clock and Trigger Inputs:

Byte clock input TTL on BNC connector. One clock and one trigger input per interface pair (each I/O channel).

Processing Power:

- Single Xeon, 2.4Ghz or better processor/ Dual PCI bus
- 512MB of RDRAM
- 10GB or better IDE system drive
- 10/100 Ethernet port
- On-board Audio
- 17" flat panel display with built in speakers

Program Storage:

Total hard drive space for Transport Stream: 72GB HD
Equivalent to 8 hours of storage at 19.39Mbits/s

Data Compatibility:

MPEG-2, DVB, ATSC, ISDB



Portable unit also available

General Specifications:

- Line Power: 100-240 Vac, 50-60 Hz
- Dimensions: 19" H x 20.5" D x 8.75" W (tower)
- Portable unit available

Ordering Information:

MAP 1853 MPEG Analyzing Platform:

MAP1853 Tower with Player/Recorder software

Hardware selection:

SINGLE-MPC MPEG Processing Card-Supports MAPASI-1

MAPASI-1 ASI Single I/O channel

or

DUAL-MPC MPEG Processing Card
(Supports up to 2 of the following I/O channel cards)

MAPASI-2 ASI Double I/O channels

MAP310M-2 SMPTE310M Double I/O channels

MAPDHEI-2 DHEI Double I/O channels

MAPLVDS-2 LVDS Parallel Double I/O channels

Applications Software Available for the MAP1853:

STREAM CREATOR MPEG Stream Creator

ISDB TOOLS ISDB Creation Tools

RT-MUX Real Time Multiplexer

RT-MPEG2 Real Time MPEG-2 Analysis

RT-IP Real Time MPEG over IP Analysis

PL-IP IP Player

RT-MHP Real Time MHP Analysis

RT-DATA Real Time Data Over MPEG Analysis

EXT-OFFLINE Extended Off-line Analysis

ES-STANDARD Standard Audio/Video ES Analysis

PS-ANALYSIS Program Stream Analysis

CC-ANALYSIS Closed Caption Analysis



For more information call:
1-800-Sencore (1-800-736-2673)
or **1-605-339-0100**
Ask for ATSC product group

Sencore, Inc.
3200 Sencore Drive
Sioux Falls, SD 57107
U.S.A.